

Model:

**TUC-48G-HC~FGD01**

**Undercounter:**

*Glass Door Refrigerator with Hydrocarbon Refrigerant*

## TUC-48G-HC~FGD01

- ▶ True's undercounter units are designed with enduring quality that protects your long term investment.
- ▶ Factory engineered system using environmentally friendly R290 hydro carbon refrigerant maintains temperature of 0.5°C to 3.3°C for the best in food preservation.
- ▶ Exterior - stainless steel front, top and ends. GalFan coated steel back.
- ▶ Interior - NSF approved, clear coated aluminum liner. Stainless steel floor with coved corners.
- ▶ Front breathing.
- ▶ Adjustable, heavy duty PVC coated shelves.
- ▶ Energy efficient, "Low-E", double pane thermal insulated glass doors.
- ▶ Foamed-in-place using a high density, environmentally friendly polyurethane insulation.



### PLAN VIEW

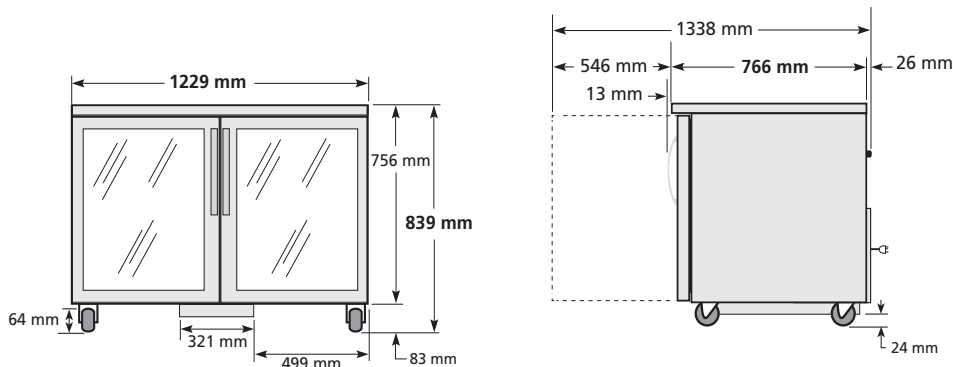

### ROUGH-IN DATA

Voltage: 220-240V/50-60Hz

Specifications subject to change without notice. Chart dimensions rounded up to the next whole millimeter (inches rounded up to the next 1/8").

Model	Model Type	Doors/Drawers	Shelves	Cabinet Dimensions (mm)			Total Display Area (m <sup>2</sup> )	EEC	EEI	Temperature Class	Annual Energy Consumption (kWh)	Crated Weight (kg)
				W	D†	H						
TUC-48G-HC~FGD01	Counter Chilled	2/0	4	1229	766	839	0,54	B	10,6	M1	682	130

† Depth does not include 26 mm for rear bumpers. Test Standard: EN23953 - Climate Class 3 (25°C, 60% relative humidity).  
Test Standard: EN23953 - Climate Class 3 (25°C, 60% relative humidity).