

Model:

T-15-1-G-1-HC~FGD01

T-Series:

Reach-In Combination Half Swing Door Refrigerator with Hydrocarbon Refrigerant



T-15-1-G-1-HC~FGD01

- ▶ True's glass door reach-in's are designed with enduring quality that protects your long term investment.
- ▶ Designed using the highest quality materials and components to provide the user with colder product temperatures, lower utility costs, exceptional food safety and the best value in today's food service marketplace.
- ▶ Factory engineered, self-contained, capillary tube system using environmentally friendly R290 hydrocarbon refrigerant that has zero (0) ozone depletion potential (ODP), & three (3) global warming potential (GWP).
- ▶ High capacity, factory balanced refrigeration system that maintains cabinet temperatures of 0.5°C to 3.3°C for the best in food preservation.
- ▶ LED interior lighting provides more even lighting throughout the cabinet. Safety shielded.
- ▶ Exterior - Stainless steel front, ends and top. Corrosion resistant GalFan coated steel back.
- ▶ Energy efficient, "Low-E", double pane thermal insulated glass door.
- ▶ Adjustable, heavy duty PVC coated wire shelves.
- ▶ Positive seal self-closing door. Lifetime guaranteed door hinges.

Bottom mounted units feature:

- ▶ "No stoop" lower shelf.
- ▶ Storage on top of cabinet.
- ▶ Compressor performs in coolest, most grease free area of kitchen.
- ▶ Easily accessible condenser coil for cleaning.

PLAN VIEW

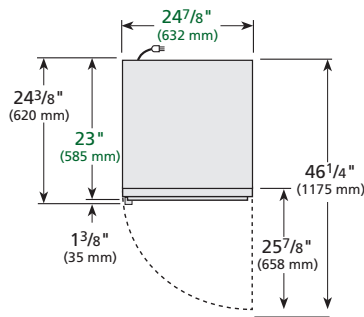
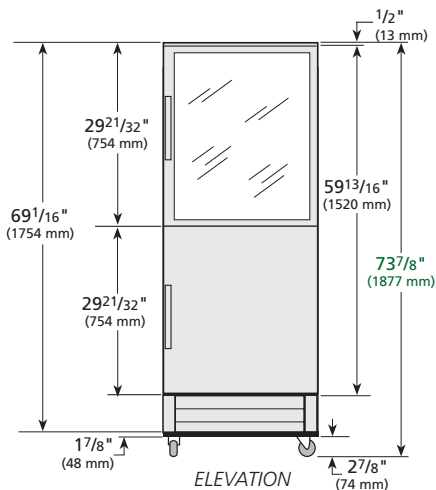

ROUGH-IN DATA

Voltage: 220-240V/50Hz

Specifications subject to change without notice. Chart dimensions rounded up to the next whole millimeter (inches rounded up to the next 1/8").

| Model | Doors | Shelves | Cabinet Dimensions (mm) | | | Net Volume (litres) | EEC | EEI | 24 hr/ Energy Consumption (kWh) | Annual Energy Consumption (kWh) | Crated Weight (kg) |
|---------------------|-------|---------|-------------------------|-----|------|---------------------|-----|------|---------------------------------|---------------------------------|--------------------|
| | | | W | D† | H | | | | | | |
| T-15-1-G-1-HC~FGD01 | 2 | 5 | 632 | 585 | 1877 | 290 | D | 52.4 | 1.1559 | 569 | 109 |

† Depth does not include 41mm for glass door handles.

Test Standard: EN16825 - Climate Class 5 (40°C, 40% relative humidity).